

TECHNICAL MANUAL

**OPERATOR'S, ORGANIZATIONAL, DIRECT  
SUPPORT AND GENERAL SUPPORT  
MAINTENANCE MANUAL INCLUDING  
REPAIR PARTS LIST**

FOR

**TEST SET, DIESEL  
MODEL DT-1300  
KIENE DIESEL  
ACCESSORIES, INC.  
(NSN 4910-00-317-8265)**

TECHNICAL MANUAL }  
}

No. 9-4910-698-14&amp;P

HEADQUARTERS  
DEPARTMENT OF THE ARMY  
WASHINGTON, DC, 10 April 1981OPERATOR'S, ORGANIZATIONAL, DIRECT SUPPORT  
AND GENERAL SUPPORT MAINTENANCE MANUAL  
INCLUDING REPAIR PARTS LIST

FOR

Test Set, Diesel

Model DT-1300

(NSN 4910-00-317-8265)

## REPORTING ERRORS AND RECOMMENDING IMPROVEMENTS

You can help improve this manual. If you find any mistakes or if you know of a way to improve the procedures, please let us know. Mail your letter, DA Form 2028 (Recommended Changes to Publications and Blank Forms), or DA Form 2028-2, located in the back of this manual direct to: Commander, US Army Armament Materiel Readiness Command, ATTN: DRSAR-MAS, Rock Island, IL 61299. A reply will be furnished directly to you.

## NOTE

This manual is published for the purpose of identifying an authorized commercial manual for the use of the personnel to whom this test set is issued.

Manufactured by: Kiene Diesel Accessories, Inc.  
325 S. Fairbanks Street  
Addison, IL 60101

Procured under Contract No. DAAA09-78-317-8265

This technical manual is an authentication of the manufacturers' commercial literature and does not conform with the format and content specified in AR 310-3, Military Publications. This technical manual does, however, contain available information that is essential to the operation and maintenance of the equipment.

## INSTRUCTIONS FOR REQUISITIONING PARTS

## NOT IDENTIFIED BY NSN

When requisitioning parts not identified by National Stock Number, it is mandatory that the following information be furnished the supply officer.

- 1 - Manufacturer's Federal Supply Code Number - 33559
- 2 - Manufacturer's Part Number exactly as listed herein.
- 3 - Nomenclature exactly as listed herein, including dimensions, if necessary.
- 4 - Manufacturer's Model Number - Model DT-1300
- 5 - Manufacturer's Serial Number (End Item)
- 6 - Any other information such as Type, Frame Number, and Electrical Characteristics, if applicable.
- 7 - If DD Form 1348 is used, fill in all blocks except 4, 5, 6, and Remarks field in accordance with AR 725-50.

Complete Form as Follows:

- (a) In blocks 4, 5, 6, list manufacturer's Federal Supply Code Number - 33559 followed by a colon and manufacturer's Part Number for the repair part.
- (b) Complete Remarks field as follows:
  - Noun: (nomenclature of repair part)
  - For: NSN: 4910-00-317-8265
  - Manufacturer: Kiene Diesel Accessories, Inc.

Model: DT-1300  
Serial: (of end item)

Any other pertinent information such as Frame Number, Type, Dimensions, etc.

**I N S T R U C T I O N S & P A R T S L I S T**  
**M O D E L D T - 1 3 0 0**  
**D I E S E L H Y D R A U L I C - T E S T E R**



# INSTRUCTIONS

## DIESEL TESTER

### MODEL DT-1300

**IMPORTANT:** Prior to putting this new tester into use, familiarize yourself with the following instructions. Since the tester is capable of developing very high pressures, improper use could result in damage to instrument or injury to operator.

1. Thread HANDLE (Item 11) into CAM (Item 10).
2. PUMP VALVE (Item 19)
  - a. Turning valve clockwise until it seats shuts the tester off, giving a true leakage reading of the device being tested.
  - b. Turn valve two or three turns counter-clockwise off its seat for normal pump operation.
3. GAGE VALVE (Item 20)
  - a. To apply pressure to a device without overloading gage, turn the valve clockwise until it seats. This position is used to protect gage from hydraulic shock.
  - b. To test any device, using the gage, turn valve counter-clockwise to a neutral position, approximately one turn off its seat.
  - c. To release pressure on the test system, continue turning gage valve counter-clockwise until pressure is released. Screw valve in (clockwise) again in preparation for the next test.
4. **CAUTION:** Continuous testing in the upper 1/5 of gauge scale and severe hydraulic shocks without gage valve closed could result in reduced gage life. Avoid when possible.
5. QUICK-CHANGE GAGE (Item 21)

Before interchanging gages, release existing pressure on gage to avoid damage to instrument. Place fingers in semi-circular opening under gage housing and push Gage (Item 21) and Adapter Assembly (Item 22) up and out. To install another gage, merely reverse procedure, pressing gage in from the top.
6. PUMP OUTPUT CAPACITY -  $1300\text{mm}^3$  (1.3 cc) per stroke at 7500 psi.
7. FILTER (Item 4)

The tester is equipped with a very fine (3 to 5 Microns) filter which will remove any dirt that may be in the fluid. The use of clean fluid will insure longer service and life of filter.
8. FILLER PLUG (Item 15) must be left loose while tester is in operation to allow air to enter fluid reservoir.
9. Before transporting, close pump and gage valves and filler plug to avoid leakage.
10. Remove filler plug (Item 15) and fill with fluid desired for testing. Reservoir capacity - Approximately 1/2 gallon.
11. Operate pump handle until air is purged from the system as evidenced by fluid emitting from discharge connection (Item 35). This step is also necessary in the event the tester runs completely out of fluid.
12. **IMPORTANT:** When dealing with high pressures and precision parts the introduction of dirt is very harmful. Be sure all connecting apparatuses are clean before attachment to device to be tested. The simplest and best way to do this is to pump fluid through them with the tester.
13. CAM (Item 10) surface and DOWEL (Item 9) should be lubricated every 10 to 20 hours of tester use.
14. Keeping above instructions in mind will assure trouble free operation and efficient service in a wide variety of tests.

**INSTRUCTIONS & PARTS LIST  
UNIT INJECTOR TEST STAND  
MODELS TS-10 & TS-15**

# UNIT INJECTOR TEST STANDS

MODELS TS-10 & TS-15

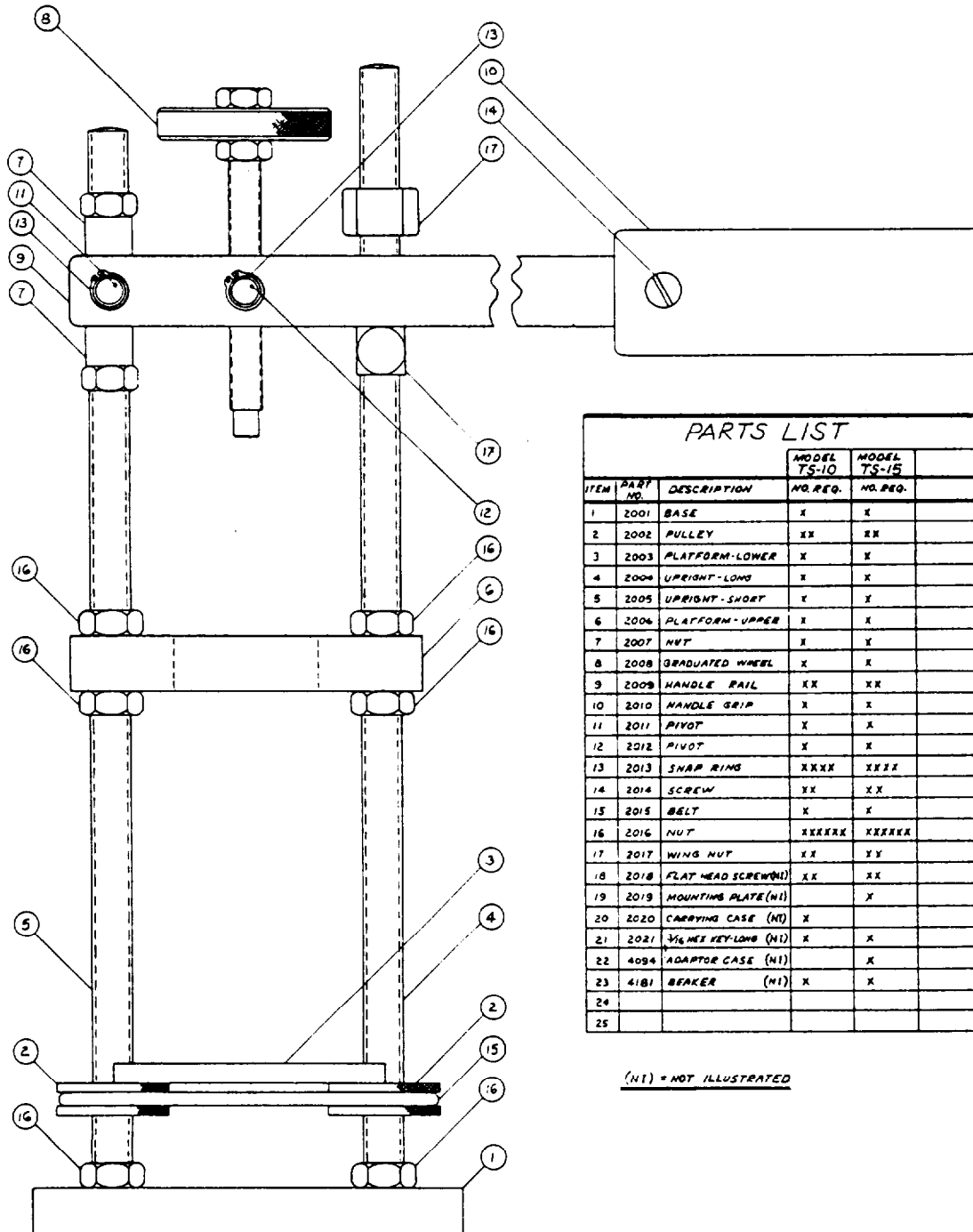

**PARTS LIST**

ITEM	PART NO.	DESCRIPTION	MODEL	MODEL
			TS-10	TS-15
			NO. REQ.	NO. REQ.
1	2001	BASE	X	X
2	2002	PULLEY	XX	XX
3	2003	PLATFORM-LOWER	X	X
4	2004	UPRIGHT-LONG	X	X
5	2005	UPRIGHT-SHORT	X	X
6	2006	PLATFORM-UPPER	X	X
7	2007	NUT	X	X
8	2008	GRADUATED WHEEL	X	X
9	2009	HANDLE RAIL	XX	XX
10	2010	HANDLE GRIP	X	X
11	2011	PIVOT	X	X
12	2012	PIVOT	X	X
13	2013	SNAP RING	XXXX	XXXX
14	2014	SCREW	XX	XX
15	2015	BELT	X	X
16	2016	NUT	XXXXXX	XXXXXX
17	2017	WING NUT	XX	XX
18	2018	FLAT HEAD SCREW(NI)	XX	XX
19	2019	MOUNTING PLATE (NI)		X
20	2020	CARRYING CASE (NI)	X	
21	2021	3/16 HEX KEY-LONG (NI)	X	X
22	4094	ADAPTOR CASE (NI)		X
23	4181	BEAKER (NI)	X	X
24				
25				

(NI) = NOT ILLUSTRATED



UNIT INJECTOR TEST EQUIPMENT

MODEL TS-10

- INCLUDES -

BASIC PORTABLE UNIT INJECTOR TEST STAND

BASIC STAND SHOWN ON BULLETIN  
METAL CASE FOR ADAPTERS.....  
GRADUATED SPRAY CUP.....  
OPERATING INSTRUCTIONS.....

MODEL TS-15

BASIC BENCH-MOUNTED UNIT INJECTOR TEST  
STAND

BASIC STAND SHOWN ON BULLETIN  
METAL CARRYING CASE FOR.....  
STAND AND ADAPTERS.....  
GRADUATED SPRAY CUP.....  
OPERATING INSTRUCTIONS.....

ADAPTERS AND CONNECTIONS REQUIRED  
FOR USE WITH BASIC TEST STAND

The following sheets show the adapters and connections listed by engine makes and models, with the corresponding tests that can be accomplished. All fuel connections convert the injector fuel connection to 14-1.5 mm male thread. A hydraulic test pump (such as the DT-1300) with a high, pressure line is necessary to supply pressurized fuel to the above mentioned 14-1.5 mm fuel connection.

SETTING UP THE TS-10

The TS-10 is packed in its own metal carrying case. Prior to removing the stand from the case, note the packing arrangement for future re-packing. The TS-10 is packed in four components (DESCRIBED BELOW).

<u>COMPONENT</u>	<u>DESCRIPTION</u>	<u>ITEMS</u>
1.	Upright and Platform Assembly	1 thru 7 & 15 thru 17
2.	Operating Wheel	8
3.	Handle Assembly	9 thru 14
4.	Carrying Case	20

ASSEMBLY

1. Remove lid from carrying case (ITEM 20). Attach upright and platform assembly base (ITEM 1) to lid with screws (ITEM 18) using wrench (ITEM 21). Tighten securely.
2. Thread operating wheel into handle assembly pivot (ITEM 12).
3. Remove upper nut (ITEM 7), place pivot (ITEM 11) of operating wheel and handle assembly on upright (ITEM 5) as shown in illustration and replace nut (ITEM 7). The basic stand is ready for use.
4. For disassembly, simply reverse the above procedure.

SETTING UP THE TS-15

The TS-15 is packed in four components (DESCRIBED BELOW).

<u>COMPONENT</u>	<u>DESCRIPTION</u>	<u>ITEMS</u>
1.	Upright & Platform Assembly	1 thru 7 & 15 thru 17
2.	Operating Wheel	8
3.	Handle Assembly	9 thru 14
4.	Mounting Plate	19

ASSEMBLY

1. Mounting plate (ITEM 19) has four 5/16" dia. bolt holes on a rectangular pattern 4-5/8" x 7-5/8". Attach upright and platform assembly base (ITEM 1) to mounting plate with screws (ITEM 18) using wrench (ITEM 21). Tighten securely.
2. Thread operating wheel into handle assembly pivot (ITEM 12).
3. Remove upper nut (ITEM 7), place pivot (ITEM 11) of operating wheel and handle assembly on upright (ITEM 5) as shown in illustration and replace nut (ITEM 7). The basic stand is ready to be permanently mounted to a bench.

## GENERAL OPERATING INSTRUCTIONS

TM 9-4910-698-14&P

1. Graduated adjusting Wheel (ITEM 8) has fifty (50) graduations. Each mark is equal to .001 of an inch, in up or down motions. When additional leverage is required, a 3/4" wrench can be applied to the hex on the operating wheel.
2. Wing nuts (ITEM 17), when positioned perpendicular to the handle (ITEM 9) limit its stroke and when positioned parallel to the handle, allows it to pass.
3. Lower platform (ITEMS 2, 3 and 15) can be moved to any height desired by rotating the pulleys (ITEM 2). The belt (ITEM 15) simply keeps the platform level. If it becomes necessary to relevel the platform remove the belt, rotate the pulleys up or down to the nuts (ITEM 16) and replace the belt.
4. All mounting adapters, fuel connections, etc. are listed on the charts attached to these instructions, with their respective engine makes, models, tests and part numbers. All mounting adapters are placed on the upper platform (ITEM 6).
5. By properly positioning the lower platform, handle assembly and graduated wheel all injectors shown on the following charts can be accommodated.

## SPECIAL OPERATING INSTRUCTIONS

### GENERAL MOTORS

See chart for proper apparatus and General Motors manual for procedures on all standard tests. The plunger and bushing tests are as follows: Select proper holding nut, and bushing adapter from chart. Place bushing adapter on lower platform; set holding nut on bushing adapter, with smaller diameter up. Remove nut, check valve, etc., from Injector. Feed injector through upper platform into bushing adapter. Thread holding nut on injector. Adjust lower platform accordingly. Tighten holding nut with wrench (ITEM 21). Adjust handle and operating wheel to obtain plunger to bushing relationship desired.

### CUMMINS

See chart for proper apparatus and Cummins Manual for procedures on all standard tests. The drip hose is used between the injector and the pump reservoir filler hole. The hold down sleeves are used to hold the injectors securely in place while having the injector plunger off its seat. The hold down sleeves are also used as a socket between the top of the injector and the operating wheel screw, by threading the hold down sleeve nut in. With the hold down sleeve not in this position, the plunger can be bottomed for the seat test. The tip cap assembly is used on all plunger leakage and seat tests. This assembly is used on the lower platform and the platform is positioned accordingly.

### HARVESTER AND MURPHY

See chart for proper apparatus and manufacturers' manuals for standard procedures.

ENGINE MANUFACTURER	ENGINE DESIGNATION	TESTS THAT CAN BE ACCOMPLISHED	ITEMS REQUIRED FOR THESE TESTS	PART NUMBER
GENERAL MOTORS	53 & 71 SERIES STANDARD & OFFSET	SPRAY PATTERN VALVE OPENING PRESSURE BINDING PLUNGER HOLDING PRESSURE HIGH PRESSURE RACK FREENESS	MOUNTING ADAPTOR FUEL CONNECTION SPRING CAP	4130 4036 4135
	(SPHERICAL VALVE)	PLUNGER & BUSHING	BUSHING ADAPTOR	4147
	110 SERIES STANDARD & OFFSET	SPRAY PATTERN VALVE OPENING PRESSURE BINDING PLUNGER HOLDING PRESSURE HIGH PRESSURE RACK FREENESS	MOUNTING ADAPTOR FUEL CONNECTION SPRING CAP	4131 4036 4037 4136
	(SPHERICAL VALVE)	PLUNGER & BUSHING	BUSHING ADAPTOR	4148
	268 SERIES (SPHERICAL VALVE)	SPRAY PATTERN VALVE OPENING PRESSURE BINDING PLUNGER HOLDING PRESSURE HIGH PRESSURE RACK FREENESS	MOUNTING ADAPTOR FUEL CONNECTION SPRING CAP	4132 4038 4137
		PLUNGER & BUSHING	BUSHING ADAPTOR	4149
	278 SERIES (SPHERICAL VALVE)	SPRAY PATTERN VALVE OPENING PRESSURE BINDING PRESSURE HOLDING PRESSURE HIGH PRESSURE RACK FREENESS	MOUNTING ADAPTOR FUEL CONNECTION SPRING CAP	4133 4039 4137
		PLUNGER & BUSHING	BUSHING ADAPTOR	4150
	567 & 645 SERIES (SPHERICAL VALVE)	SPRAY PATTERN VALVE OPENING PRESSURE BINDING PRESSURE HOLDING PRESSURE HIGH PRESSURE RACK FREENESS	MOUNTING ADAPTOR FULL CONNECTION SPRING CAP	4133 4142 4137
		PLUNGER & BUSHING	BUSHING ADAPTOR	4150

ENGINE MANUFACTURER	INJECTOR DESIGNATION	TESTS THAT CAN BE ACCOMPLISHED	ITEMS REQUIRED FOR THESE TESTS	
CUMMINS	A & J SINGLE AND DOUBLE DISC PUMPS  J & C PT SYSTEMS (FLANGED BODY)	SPRAY PATTERN CHECK VALVE (NOT ON "PT") PLUNGER LEAKAGE PLUNGER SEAT	HOLD DOWN SLEEVE MOUNTING ADAPTOR  FUEL CONNECTIONS  DRIP HOSE TIP CAP ASSEMBLY	4126 4119  (4122 (4123 (4178  4157 4121
	H & NH SINGLE AND DOUBLE DISC PUMPS  H & NH PT SYSTEM (FLANGED BODY)	SPRAY PATTERN CHECK VALVE (NOT ON "PT") PLUNGER LEAKAGE PLUNGER SEAT	HOLD DOWN SLEEVE MOUNTING ADAPTOR  FUEL CONNECTIONS  DRIP HOSE TIP CAP ASSEMBLY	4127 4120  (4122 (4123 (4178  4157 4121
	K & L SINGLE AND DOUBLE DISC PUMPS  L SERIES PT SYSTEM (FLANGED BODY)	SPRAY PATTERN CHECK VALVE (NOT ON "PT") PLUNGER LEAKAGE PLUNGER SEAT	HOLD DOWN SLEEVE  FUEL CONNECTIONS  DRIP HOSE TIP CAP ASSEMBLY	4128  (4124 (4125  4157 4121
	J, C, H & NH PT SYSTEM CYLINDRICAL "O" TYPES  PT PT TYPE B PT TYPE C	SPRAY PATTERN BALL CHECK (TYPES B & C) PLUNGER LEAKAGE PLUNGER SEAT	HOLD DOWN SLEEVE MOUNTING ADAPTOR GAG NUT TIP CAP ASSEMBLY	4127 4183 4169 4121
	INTERNATIONAL HARVESTER	817 SERIES	SPRAY PATTERN VALVE OPENING PRESSURE INJECTOR ASSEMBLY LEAKAGE PLUNGER & BUSHING LEAKAGE SEAL LEAKAGE	MOUNTING ADAPTOR  FUEL CONNECTIONS  SPRING CAP
MURPHY		ALL MURPHY (CYLINDRICAL "O" TYPE)	SPRAY PATTERN VALVE OPENING PRESSURE BINDING PLUNGER HOLDING PRESSURE	MOUNTING ADAPTOR PUSH PIN  4167 4168

By Order of the Secretary of the Army:

Official:

E. C. MEYER  
General, United States Army  
Chief of Staff

J. C. PENNINGTON  
Major General, United States Army  
The Adjutant General

\*U. S. GOVERNMENT PRINTING OFFICE: 1981-703-029/1030

RECOMMENDED CHANGES TO EQUIPMENT TECHNICAL PUBLICATIONS



THEN... JOT DOWN THE DOPE ABOUT IT ON THIS FORM, CAREFULLY TEAR IT OUT, FOLD IT AND DROP IT IN THE MAIL!

**SOMETHING WRONG WITH THIS PUBLICATION?**

FROM: (PRINT YOUR UNIT'S COMPLETE ADDRESS)

DATE SENT

PUBLICATION NUMBER

TM 9-4910-698-14&P

PUBLICATION DATE

10 April 1981

PUBLICATION TITLE

Maintenance Manual for Diesel Test Set - Model DT-1300

BE EXACT... PIN-POINT WHERE IT IS

PAGE NO	PARA-GRAPH	FIGURE NO	TABLE NO

IN THIS SPACE TELL WHAT IS WRONG AND WHAT SHOULD BE DONE ABOUT IT:

TEAR ALONG PERFORATED LINE

PRINTED NAME, GRADE OR TITLE, AND TELEPHONE NUMBER

SIGN HERE:

DA FORM 2028-2  
1 JUL 79

PREVIOUS EDITIONS ARE OBSOLETE.

P.S.-IF YOUR OUTFIT WANTS TO KNOW ABOUT YOUR RECOMMENDATION MAKE A CARBON COPY OF THIS AND GIVE IT TO YOUR HEADQUARTERS.

FILL IN YOUR  
UNIT'S ADDRESS

FOLD BACK

DEPARTMENT OF THE ARMY

\_\_\_\_\_  
\_\_\_\_\_

OFFICIAL BUSINESS  
PENALTY FOR PRIVATE USE \$300

POSTAGE AND FEES PAID  
DEPARTMENT OF THE ARMY  
DOD 314



TEAR ALONG PERFORATED LINE

Commander  
US Army Armament Materiel Readiness Command  
ATTN: DRSAR-MAS  
Rock Island, IL 61299



**TM 9-4910-698-14&P - TEST SET, DIESEL  
(KIENE DIESEL ACCESSORIES, INC.) (NSN 4910-00-317-8265) — 1981**